

# **THE IMPACTS OF USING SNSs ON E-WOM AND KNOWLEDGE SHARING THROUGH SOCIAL CAPITAL: AN EMPIRICAL STUDY IN VIETNAM**

***Quoc Trung Pham, Vi Khiết Huynh \****

School of Industrial Management, Bach Khoa University (VNU-HCM),  
Ho Chi Minh City, Vietnam

## **ABSTRACT**

Nowadays, Social Networking Sites (SNSs) have attracted billions of users all around the world. In Vietnam, SNSs become more and more familiar with Vietnamese people and Facebook is the most popular SNS. Social Capital is an important term in the study and social behavior, an important sector in the major universities of the world. However, Social Capital is still very vague concept, not only for citizens but also for policy makers in Vietnam. There are a few of studies have examined the impact of SNSs to Social Capital and Knowledge Sharing through word of mouth in environment of SNSs (e-WOM) in Vietnam. Based on previous research model, this research examines whether the intensity of using SNSs has a positive impact on users' Social Capital, Knowledge Sharing and e-WOM. A survey was conducted with Facebook users in Vietnam. The regression analysis was utilized to examine the nine main hypotheses through a questionnaire designed which is based on the Likert five-point scale. The results show that the intensity of using SNSs raise the Trust and Identification dimension of Social Capital, especially the Trust, and these dimensions have positive effects to e-WOM Quality on SNSs. It also finds out that the e-WOM Quality impacts positively on Knowledge Sharing through SNSs environment in Vietnam.

**Keywords:** E-WOM, SNS, Knowledge Sharing, Social Capital, Vietnam

---

\* Corresponding author e-mail address: [huynhvikhiety@gmail.com](mailto:huynhvikhiety@gmail.com)

## INTRODUCTION

The explosion of Information Technology has brought the tremendous changes of the socio-economic in the world. Today, web 2.0 creates new method of approaches for marketing or business industry and being a tool which supports knowledge sharing management (Lee, 2011). Based on Web 2.0, the one of most utilized services is so-cial media , which is defined as a network of Internet-based applications that create based on the ideological and technological foundations of Web 2.0, and that enables the creation and exchange of user-generated content. It includes social network sites (SNSs) (Chu et al., 2011). The development of SNSs has formatted the way of connecting and interacting. The SNSs are defined as Websites that helps users to connect with other people and share their statuses and activities (Donath and Boyd, 2004).

Social capital is “the resource available to actors as a function of their location in the structure of their social relations” (Adler et al., 2002). The word of mouth (WOM) is one of the most important methods for giving and receiving information in social (Godes et al., 2004). The WOM has many forms, such as traditional WOM (offline form) and via Internet WOM (e-WOM) (Steffes et al., 2009). There are differences between traditional WOM and e-WOM although they are expected to be relevant (Hennig-Thurau et al., 2004). Traditional WOM is type of an immediate conversation, while e-WOM is a type of asynchronous interactions among people which is separated by time and space (Steffes et al., 2009). This research examines e-WOM, because it works in social networking environments, and SNSs are a perfect tool for checking e-WOM (Chu et al., 2011).

Organizations have utilized SNSs for networking and collaboration. IBM and Microsoft use social networking tools to have strengthened weak link among colleagues Huang et al., 2010). IBM has also used SNSs for keeping their employees contact, fulfill generation gaps, and encourage the innovating and collaborating (Majchrzak et al., 2009). Social networking tools are the good media to allow people interface together anywhere, any time (Majchrzak et al., 2009). Company can improve their innovation processes via their customer (Leimeister et al., 2009). Social networking tools also support the firms to improve interactions with their customers for crowdsourcing. Example Starbucks, SNSs have been utilized for contacting with customers, informing them about promotions, getting the suggestions and tracking consumer-to-consumer dialog (Gallaughier et al., 2010).

Many researchers have studied SNSs, their influence and practical usage. However, a few of paper research have examined the influence between SNSs,

social capital, knowledge sharing, and e-WOM. Although there are some previous researches found out that WOM quality has a positive impacts on online Trust (Awad et al., 2008), the scenario has not been on SNSs. Furthermore, there is little research that has examined the influence of social capital, knowledge sharing to e-WOM on SNSs. Therefore, this paper's purpose is closing these research gaps by examining the impact of Intensity of Use of SNSs to users' Social Capital, Knowledge Sharing and e-WOM.

In Vietnam, Facebook is one of the most popular social network sites. The operation of "share" and "tagging" has increased the connection among the users in Facebook. In Vietnam, 44% users have more than 400 friends and 13% more than 1000 friends. This is a big surprise for researcher because the average number of friends on Facebook is about 100 friends in Japan. Half of Vietnamese user "will accept" if they get friend requests from strangers. Unlike the eastern countries of Southeast Asia, the Vietnamese generally open to share personal information and find the information other than managing it in private.

According to Hofstede (1991), the individualism of Vietnam is different with South Korean and United States. It means the spirit of collectivism in South Korean and United States is different with Vietnam. Furthermore, the collectivism culture involves to the significant of emotional support and defined norms obtained through network social that are highlight in bonding social capital (Choi et al., 2011). Therefore, there must be a different to conduct this research in comparison with previous ones in Korea and US.

Specific research objectives of this research could be summarized as follows: (1) Measuring the impact of the SNS Usage Intensity to user's Social Capital, the impact of Social capital to Knowledge sharing and e-WOM, the impact of e-WOM to Knowledge sharing; and (2) Give the recommendation for promoting social development via SNSs by using its impact to e-WOM and Knowledge sharing. The structure of this paper includes: (2) definitions, (3) research model and hypotheses, (4) research process, (5) data analysis results, and (6) conclusion and implications.

## DEFINITIONS

### Web 2.0

Web 2.0 is defined as new version of WWW sites which focused on dynamic content and interaction of participants. Web 2.0 allows firms to enhance existing capabilities by integrating multiple functions including knowledge management, project management, and social networks that connect people together (Bayus et

al., 2012). In addition, Web 2.0 also enhances the capability in many activities inside of business which includes internal marketing.

### **Social Network Sites**

SNSs (belongs to Web 2.0) are web-based services that enable individuals to: (a) cre-ate a profile within a bounded system, (b) link a list of their friends, and (c) review and track their list of connections and those made by others within the system (Boyd et al., 1999). SNSs are considered the main source of creating social capital in modern organizations. However, the real impact of SNSs using on social capital of an organi-zation is not known completely.

### **Social Capital**

Social capital refers to intangible capital inside of an organization, which relating to the relationship between employees and customers. Social capital mentions to the collected resources through the relationships among people (Coleman, 1988). Social capital must be created from community (Nahapiet et al., 1998). The Social capital enhances the knowledge transferring process through the social interaction (Huang et al., 2010). Social capital has three dimensions: (1) the structural dimension (network bonds, network configuration, and appropriable organization), (2) the cognitive di-mension (shared codes and language, and shared descriptions), and (3), the relational dimension (trust, norms, obligations and identification) (Nahapiet et al., 1998).

### **E-WOM**

The e-WOM is any statement made by customers about a product or a company, which is made available to many people through the Internet (Hennig-Thurau et al., 2004). E-WOM effects users' experiences in both positive and negative side (Sweeney et al., 2012). E-WOM quality has largely been researched in marketing method, espe-cially on retailer websites. Nevertheless, there has been little research on e-WOM qual-ity, while there are many researches about e-WOM. In e-business, e-WOM is consid-ered a best strategy for attracting customers and conducting viral marketing. SNS members have trend to get valuable information about products or organizationns from others' feedbacks, comments, sharings... which are very helpful for them in making the decision about online purchasing.

### **Knowledge**

Knowledge is defined as "a justified belief" that increases one's capacity for doing something effectively (Alavi et al., 2001). Knowledge is a familiarity, understanding or awareness about somebody or something, such as object,

information, descriptions, facts or skills, which is collected through education or experience by learning, discovering or perceiving. Knowledge is also said to be involved in the capacity of acknowledgment in human beings.

### **Knowledge Management**

Knowledge management is defined as the system of process in organizing and managing knowledge processes, such as identifying gaps of knowledge, acquiring, developing, storing, distributing, sharing and applying the knowledge. The processes of managing knowledge has become to be critical in enhancing the performance of organizations, that can either be directed to more creation or more effectiveness. Knowledge also supplies the foundation for innovation and enhancement in organizations. (Verburg and Andriessen, 2011).

### **Knowledge Sharing**

Knowledge sharing is an important step of knowledge management process, in which one or both parties seeking and giving their knowledge, especially their tacit knowledge (know how, attitude, experience, ideas...). SNS is a good place for social interaction and sharing knowledge between members. Via SNSs, individuals can raise their opinion and also show their knowledge just in time. SNSs also enable users to communicate, exchange idea, interact and share their knowledge with other ones in naturally and friendly. SNSs create a good platform for keeping user's engagement by collect the feature, such as pages or groups.

## **RESEARCH MODEL**

This research has referred to the previous study, Choi and Scott (2013) examined the model of impacts among Using SNSs, Social capital, e-WOM and Knowledge sharing in context of United State and Korean. Besides, Adhi et al. (2014) explored whether the intensity of use of SNSs is related to users' social capital dimensions including structural, relational, and cognitive, and furthermore their relation with knowledge sharing behavior. Moreover, Hsu et al. (2013) examined how social relationship factors influence on e-WOM behaviors in SNSs. This study indicated that social capital positively impact on e-WOM behaviors, and there could be a difference in these impacts between Taiwan and Vietnam context.

In purpose to draw a full picture about these items in context of Vietnam, the research model of Choi and Scott (2013) is chosen. In Vietnam, due to specific of

hu-man, economic, social and political, this model research may not work or lead to new results which are different from other countries. This model could be summarized in the following figure.

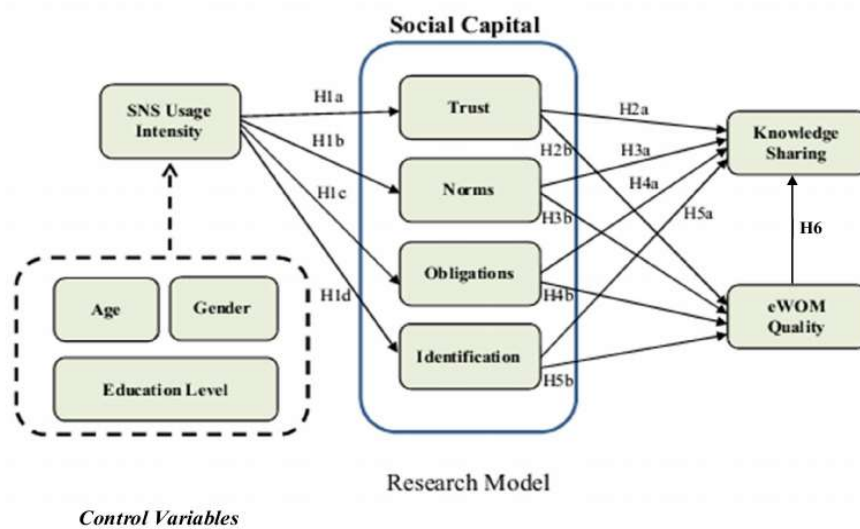

**Figure 8.1.** Research model (Source: Choi and Scott, 2013)

Trust has been examined in various industries, and this leads to occurs many definitions of trust (Hsu et al., 2007). In this research, the trust is defined as “an expecta-tion that others one chooses to trust will not behave opportunistically by taking ad-vantage of the situation” (Gefen et al., 2003). From previous study, SNSs enable social networks to be visible to people, and therefore contribute to the trust between social network members. So we hypothesize the following:

Hypothesis H1a: The SNS usage intensity positively affects to trust in SNSs.

A norm occurs when people kept the socially defined right to control their action (Nahapiet et al., 1998). A norm creates a form of social capital when it occurs and is valid (Coleman, 1988). Collaborative norms enable coordination and cooperation for mutual benefit (Putnam, 2000). A norm is a reasonable way in a community, which is supported by SNSs to overcome geographic distance. Thus, we hypothesize the following:

Hypothesis H1b: The SNS usage intensity positively affects to norms in SNSs.

Obligations are known as credit and delegate “a commitment or duty to undertake some activity in the future” (Nahapiet et al., 1998). Obligations are

different with norms because it relates to more personal relationships. Besides, previous research found out that virtual community is very important for developing obligations (Less-er et al., 2001). So we hypothesize the following:

Hypothesis H1c: The SNS usage positively affects to obligations in SNSs.

Identification is defined as the process that each members see themselves as one with other members in their group (Nahapiet et al., 1998). As a member in the community, they build up a common identity for the community (Sherif et al., 2006). In the opposition, identification promotes members to join in virtual communities (Hung et al., 2007). Previous research shows that usage of SNSs has positive impacts on identification of the group. Therefore, we hypothesize the following:

Hypothesis H1d: The SNS usage intensity positively affects to identification in SNSs.

Based on Choi and Scott (2013), social capital including trust, norms, obligations and identification has a positive influence on knowledge sharing behavior of people using SNSs. Accordingly, we suggest the following hypotheses:

Hypothesis H2a: Trust positively affects to knowledge sharing in SNSs.

Hypothesis H3a: Norms positively affects to knowledge sharing in SNSs.

Hypothesis H4a: Obligations positively affects to knowledge sharing in SNSs.

Hypothesis H5a: Identifications positively affects to knowledge sharing in SNSs.

Based on Choi and Scott (2013), social capital including trust, norms, obligations and identification has a positive influence on e-WOM quality of people who use SNSs. Accordingly, we suggest the following hypotheses:

Hypothesis H2b: Trust positively affects to e-WOM quality in SNSs.

Hypothesis H3b: Norms positively affects to e-WOM quality in SNSs.

Hypothesis H4b: Obligations positively affects to e-WOM quality in SNSs.

Hypothesis H5b: Identifications positively affects to e-WOM quality in SNSs.

There is a relationship between e-WOM quality and online purchasing behavior, but there is a lack of proof about the relationship between e-WOM quality and knowledge sharing. However, knowledge sharing depends on trust and e-WOM could be a good input for building trust between members and lead them to knowledge sharing behavior (Chang et al., 2010). We realized that if SNS users get good e-WOM from other members, then they may be encouraged to share their knowledge and want to bring benefits to their friends. As a result, we hypothesize the following:

Hypothesis H6: e-WOM quality positively affects to knowledge sharing in SNSs.

## RESEARCH PROCESS

The research will pass through two stages, Pilot (n=50) for primary test and finalize the questionnaire, and then, Quantitative phase (a survey is conducted with n=357) for testing reliability of scales and analyzing the results. Below diagram presents the entire research process with the main stages from survey which for data collection to data analysis (Cronbach Alpha test, EFA, CFA, SEM...).

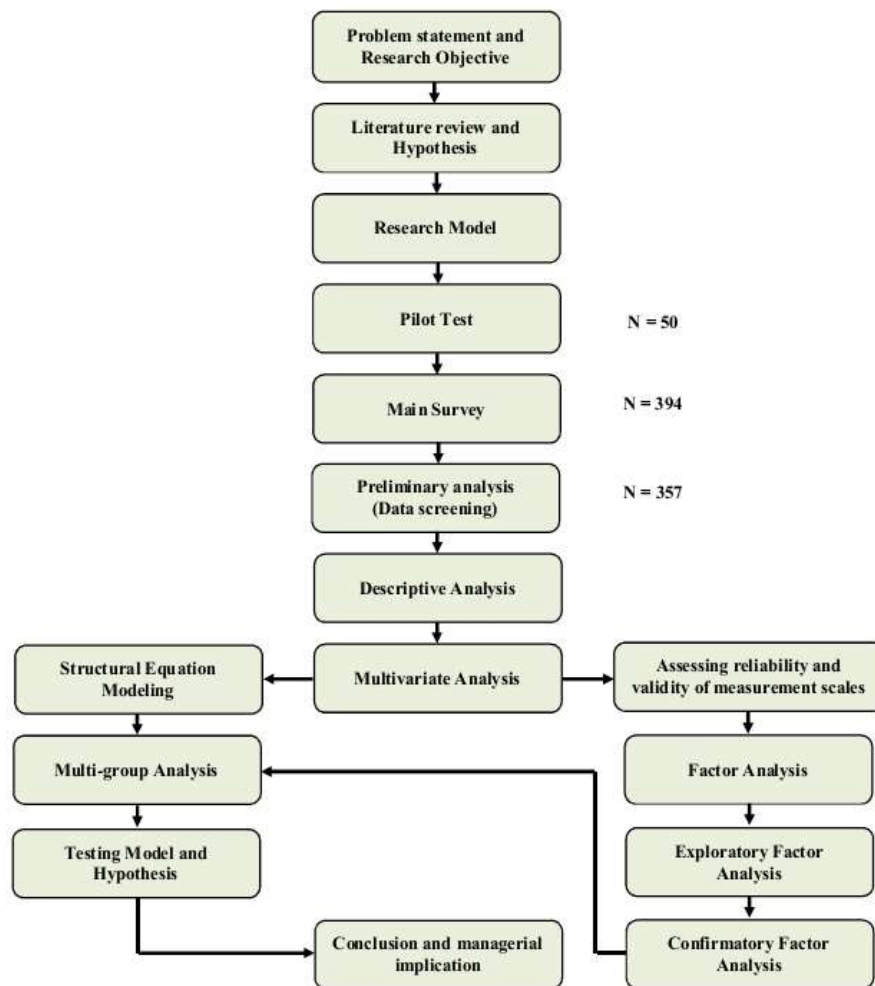

Figure 8.1. Research process



### **Measurement scales**

There are seven constructs in this research model which are SNS usage intensity, Social capital (Trust, Norms, Obligations and Identification), Knowledge sharing, and e-WOM quality. Most of the elements in these constructs are built based on Choi and Scott (2013) as discussed earlier, some findings which are not suitable from the pilot stage which are removed out of the original questionnaire. The scales which are based on English are translated to Vietnamese and major meanings of the scales are keeping. A pilot test is firstly executed with 50 respondents to check if they have any difficulty in answering them. Adjusting of scales is active after this phase.

### **Sample size and Breakdown**

Tabachnick and Fidell (2007) indicated that we need at least 300 cases for a rational factor analysis to be successfully conducted. For the specific demographic group, the size of collected sample should be larger than 30. The larger size of collected sample, the more rational and typical the results and the lower the errors. So it would consider being an acceptable sample with 357 collected ones.

### **Data analysis methods**

After collecting the data, the questionnaires are audited before being processed by the SPSS software version 20.0. Data analysis is executed by both SPSS and IBM's Analysis of Moment Structures (AMOS) version 21.0 on Windows OS. The structural process of analysis data in this research includes the below stages: Descriptive Statistics, Assessment of Measurement Scales, Exploratory Factor Analysis, Confirmatory Factor Analysis, Structural Equation Modelling for test model and hypothesis, and Bootstrap analysis.

## **DATA ANALYSIS & RESULTS**

### **Sample Description**

A total of 394 complete samples were collected including 200 responses (50%) from my Facebook friends, 127 responses (32%) from my company, and 57 re-sponses (18%) from HCM Technology University. Based on the two ways of collect-ing data, the respondent is 279 (73%) for the paper survey, and 105 (27%) for the online (link sharing) survey.

However, only 357 questionnaires (90.61%) passed through the audited step. The number of qualified questionnaires met the sample size requirement

suggested by Hair et al. (2006) to generate valid fit measurement and to avoid drawing inaccurate inference. The sample of 357 valid respondents was grouped based on their ages, genders and educational levels. Details are presented in the Table 1.

We can see that the major group of respondents was between 21 - 40 years old (total 76%); followed by the youngest group with 22.7% and the oldest group is only 1.4% - this group maybe inconsiderable. Concerning the respondent ratio between males and females, the data shows that males joined mainly the survey about 1.5 times the number of females. About the educational levels, most of the participants had university or college degrees (66.4%). Especially, Master or PhD level is fairly high in this survey (28.9%). Besides, there is not much different in the number of participants from the lower and higher in the other education groups.

**Table 8.1.** Demographic profile on Age, Gender and Educational

<b>Demographic Profile</b>		<b>Frequency</b>	<b>Percentage</b>
<b>Age (years of age)</b>	<i>Below 21</i>	81	22.7%
	<i>21-30</i>	115	32.2%
	<i>31-40</i>	156	43.7%
	<i>Above 40</i>	5	1.4%
<b>Gender</b>	<i>Male</i>	221	61.9%
	<i>Female</i>	136	38.1%
<b>Educational Degree</b>	<i>High school</i>	69	19.3%
	<i>College/ University</i>	143	40.1%
	<i>Master/PhD</i>	103	28.9%
	<i>Others</i>	42	11.8%

## **Preliminary Assessment of Measurement Scales**

### *Uni-dimensionality Test.*

The total of factors are 10 constructs, namely, SNSs Usage Intensity, Trust, Norm, Obligation, Identifications, e-WOM Quality and Knowledge Sharing with total 32 measurement items. All these constructs must be uni-dimensional that means the indicators have only one underlying construct. Analysis result shows that all constructs have matched these requirements: Eigen value greater than 1; KMO index must be above 0.5 and less than 1; Total variance explained criteria > 50%. So, the specific scales for each of these constructs are uni-dimensional.

### *Reliability Analysis.*

Cronbach's alpha coefficient of seven constructs was estimated, which ranged from 0.776 to  $\alpha = 0.887$  (before deleting unfitting items) and from 0.776 to  $\alpha =$

0.935 (after deleting unfitting items). There were three items which have corrected item-total correlation  $< 0.3$ , which demonstrates the item is presenting different thing which do not belong to the scale. They were: TRUST4 (0.294), IDENTI5 (0.174) and E-WOMQL1 (0.188).

After deleting 3 above items, the alpha value of perceived Identification, e-WOM Quality was very high, over 0.90. The other constructs –Trust, Obligations, Norms and Knowledge Sharing had also values that is higher than 0.8. The construct of SNS Usage Intensity had lowest alpha value (0.776), and the highest one (0.935) belongs to construct of Identification. In addition, there was no item had corrected item-total correlation  $< 0.3$ , which presents different thing which does not belong to the scale.

### **Exploratory Factor Analysis**

#### *Results of EFA.*

A next step of EFA with the same configuration as in previous step (example the principal axis factoring, Eigen-value must be  $\geq 1$  and method of PROMAX rotation) is executed to evaluate convergent validity and discriminant validity. The below rules must be followed for checking the outputs: Total value of cumulative variances is  $> 60\%$  ; The factors are kept for further analysis only if it has eigenvalues of at least  $\geq 1.0$  ; The absolute value of difference between its max loading value and any other loading value must be  $> 0.2$  ; Minimum factor loading value for each of indicator must be  $> 0.35$ .

#### *Revised Research Model after EFA.*

The result of above EFA step also support a revision to previous research model for better reflection of these significant factors and their effects.

According to above criteria, after above steps, seven factors have been grouped as follows: e-WOM (E-WOMQL7, E-WOMQL5, E-WOMQL6, E-WOMQL2, E-WOMQL4 and E-WOMQL3) ; Trust (TRUST2, TRUST6, TRUST5, TRUST3 and TRUST1) ; Identifications (IDENTI2, IDENTI1, IDENTI3 and IDENTI4) ; Obligations (OBLIGA5, OBLIGA1, OBLIGA4, OBLIGA2 and OBLIGA3) ; Knowledge Sharing (KNOWSH1, KNOWSH5, KNOWSH4, KNOWSH2 and KNOWSH3) ; Norms (NORMSC3, NORMSC1 and NORMSC2) ; SNS Usage Intensity (SNSUIN2, SNSUIN1 and SNSUIN3).

### **Final Assessment of Measurement Scales Using CFA**

The CFA Model analysis result showed that all criteria are satisfied (Chi-square/df $<2$ , GFI,TLI,CFI $>0.9$ , RMSEA $<0.05$ ). Therefore, model is fit with data.

#### *Composite Reliability, Convergent Validity and Discriminant Validity.*

Table below shows the results of CR, AVE scores each pair of the constructs.

**Table 8.2.** CR, AVE scores and correlation scores

	CR	AVE
SNSUIN	0.778	0.540
E-WOMQL	0.930	0.690
KNOWSH	0.807	0.458
OBLIGA	0.875	0.585
TRUST	0.890	0.620
IDENTI	0.935	0.784
NORMSC	0.865	0.683

*Assessment of Model Fit.*

The overview of the model fit measured by AMOS showed that the full measurement model has reached a good fit with the data. Measurement model consistent with market data and no case of errors of the observed variables are correlated with each other, thus turning the pair agency monitoring achieving unitary (Steenkamp and van Trijp, 1991).

**Test Model and Hypothesis Using SEM**

The SEM model contained the regressions of the relation between six potential con-structs, they are: TRUST, NORMMSC, IDENTI, OBLIGA, E-WOMQL and KNOWSH and the dependent potential construct SNSUIN, which is formed based on the final output from CFA analysis with the paired arrows from determined latent constructs. These potential constructs are calculated by multi-item scales and each of items may have its own error limit as shown in the figure and table below.

**Table 8.3.** Regression Weights

		Estimate	S.E.	C.R.	P	Label
TRUST	<--- SNSUIN	.427	.072	5.956	***	
NORMSC	<--- SNSUIN	-.129	.075	-1.725	.085	
OBLIGA	<--- SNSUIN	.040	.047	.860	.390	
IDENTI	<--- SNSUIN	.206	.079	2.598	.009	
EWOMQL	<--- TRUST	.408	.046	8.777	***	
EWOMQL	<--- NORMSC	.044	.041	1.086	.277	
EWOMQL	<--- OBLIGA	-.056	.065	-.863	.388	
EWOMQL	<--- IDENTI	.093	.036	2.616	.009	
KNOWSH	<--- TRUST	.027	.038	.695	.487	
KNOWSH	<--- NORMSC	.047	.031	1.507	.132	
KNOWSH	<--- OBLIGA	-.035	.050	-.698	.485	
KNOWSH	<--- IDENTI	.036	.027	1.326	.185	
KNOWSH	<--- EWOMQL	.315	.052	6.087	***	

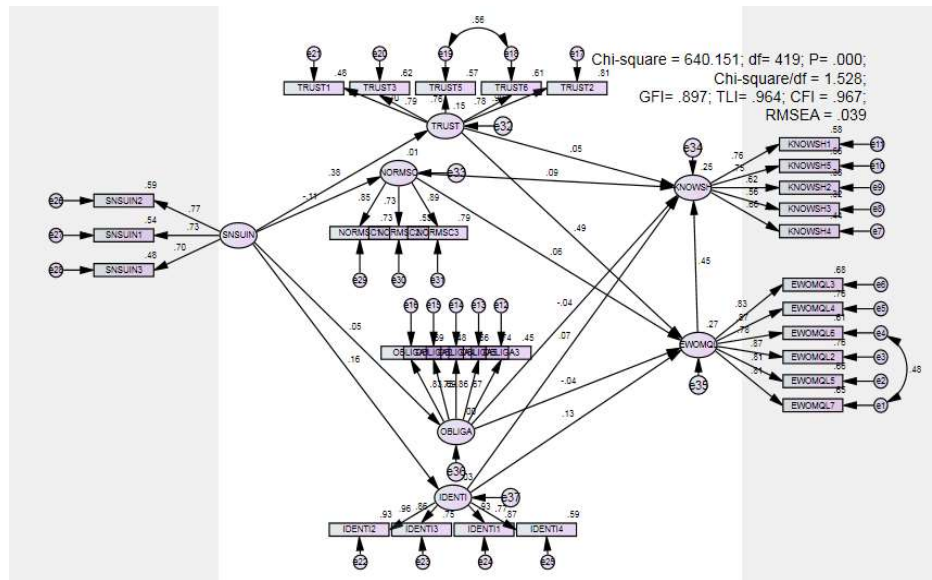

*Estimated test of the model by Bootstrap analysis:*

After executing SEM analysis, Bootstrap analysis method is used to evaluate the reliability of the estimators. Number of repeat sampling in this research was chosen B = 500. Bootstrap estimation result is showed in below Table.

**Table 8.4.** Bootstrap Analysis

Parameter	SE	SE-SE	Mean	Bias	SE-Bias	CR
TRUST <--- SNSUIN	0.058	0.002	0.378	-0.003	0.003	-1
NORMSC <--- SNSUIN	0.073	0.002	-0.111	-0.001	0.003	-0.33333
OBLIGA <--- SNSUIN	0.08	0.003	0.052	-0.002	0.004	-0.5
IDENTI <--- SNSUIN	0.066	0.002	0.153	-0.005	0.003	-1.66667
E-WOMQL <--- TRUST	0.049	0.002	0.489	-0.004	0.002	-2
E-WOMQL <--- NORMSC	0.055	0.002	0.054	-0.002	0.002	-1
E-WOMQL <--- OBLIGA	0.056	0.002	-0.045	0	0.003	0
E-WOMQL <--- IDENTI	0.057	0.002	0.126	-0.004	0.003	-1.33333
KNOWSH <--- TRUST	0.068	0.002	0.047	0.001	0.003	0.333333
KNOWSH <--- NORMSC	0.057	0.002	0.089	0.003	0.003	1
KNOWSH <--- OBLIGA	0.072	0.002	-0.034	0.005	0.003	1.666667
KNOWSH <--- IDENTI	0.058	0.002	0.071	-0.001	0.003	-0.33333
KNOWSH <--- E-WOMQL	0.066	0.002	0.444	-0.005	0.003	-1.66667

In summary, these measures show that the model has fits with the collected data and it could be used to present for the above hypotheses.

*Testing of Hypotheses:*

The research hypotheses are continued to test and the result is as follows:

**Table 8.5.** Hypothesis Testing Results

Hypothesis	Supported	Estimates	t-statistics
SNS usage intensity --> Trust	<b>Yes</b>	<b>0.427</b>	<b>5.956</b>
SNS usage intensity --> Norms	No	-0.129	-1.725
SNS usage intensity --> Obligations	No	0.04	0.860
SNS usage intensity --> Identification	<b>Yes</b>	<b>0.206</b>	<b>2.598</b>
Trust --> Knowledge Sharing	No	0.27	0.695
Trust -->e-WOM Quality	<b>Yes</b>	<b>0.408</b>	<b>8.777</b>
Norms -->Knowledge Sharing	No	0.47	1.507
Norms -->e-WOM Quality	No	0.044	1.086
Obligations --> Knowledge Sharing	No	-0.035	-0.698
Obligations -->e-WOM Quality	No	-.056	-0.863
Identification --> Knowledge Sharing	No	0.036	1.326
Identification -->e-WOM Quality	<b>Yes</b>	<b>0.093</b>	<b>2.616</b>
e-WOM Quality --> Knowledge Sharing	<b>Yes</b>	<b>0.315</b>	<b>6.087</b>

*Multi-group Analysis:*

Chi-square test showed that there is no difference between Unconstrained Model and Constrained Model (P-value > 0.05). Therefore Constrained Model would be selected for analysis (due to higher degrees of freedom).

As a result, we conclude that there is no significant difference between Male and Female in regard to their perception of how different factors affect their using SNSs, E-WOM and Knowledge Sharing behaviors.

## DISCUSSION

Basically, this study has the similar result with previous study (Choi and Scott, 2013). The SNS usage intensity has positive impact to both of dimension of Social Capital: Trust and Identification. The next finding is two these dimensions have main effects to e-WOM on SNSs space in Vietnam. The final result shows that Vietnamese people also think that e-WOM have good impact for Knowledge Sharing through SNSs environment. So, based on this result, some managerial implications for Vietnamese businesses, government, and SNS providers could be made as follows:

### **For Vietnamese businesses:**

First, it is a good foundation for organization: building the Trust and Identification among employees in the organization. The organization could use SNSs as a tool to build the Trust among employees and enlarge Identification in

the organization. The organization could increase social interaction and shared vision in order to encourage knowledge sharing through SNSs.

Second, this result could also provide the foundation for practitioners to use e-WOM on SNSs internally for building network and community to support knowledge management in organization.

Third, users could use SNSs for supporting knowledge sharing in problem solving activities, such as software coding, technical supporting, or customer helping.

Fourth, marketers also use the e-WOM as a marketing tool on SNSs. SNS could be good channel for firm to collect the feedbacks from customers. In positive side, these feedbacks are the priceless information for firm in improving or creating its product or service. On the other sides, many challenges that the firm could be faced. For example, in Vietnam, the organizations may face the risk which is dirty tricks from its competitors through SNSs or they cannot handle and adapt customers' opinions or complaint (Gallaughier et al., 2010).

#### **For the Vietnamese government:**

Some point of times, the Vietnamese authorities want to restrict using Facebook, they give some reasons: such as wasting working time, the risk of spread unhealthy information, Religious or regions conflicts, phishing or security online, crowd psychology... But Facebook reflects the real social; there have two sides of the object: positive side and negative side and the task of social managers should be restricting the negative side and enhancing the positive side of Facebook. There are many advantages and valuable effect for social:

- Connecting communities
- Orienting the information which is transmitted to citizen via SNSs based on their demographic: gender, age, kind of job, level of education...
- Building the Trust and Identifications dimensions in social.
- Improving the social policy.
- Spread legal Knowledge and social Knowledge.

#### **For Vietnamese providers of social networking services:**

Creating virtual space with strong belief of members which is based on specific feature of group: age, hobby, interests... Based on this, they can build the Trust from the using SNSs.

Using network to collaborate among members for solving issue, sharing useful information...

The SNS management should focus more on how to create suitable policies for building the Trust dimension on online environment.

SNSs management also builds the platform that allows the member can share/public their skills/knowledge easily.

## CONCLUSION & FUTURE RESEARCH

In summary, this study finds out that the SNS usage intensity has a positive impact on Social capital (including: trust and identification), which will have a positive im-pact on e-WOM quality. The more people use their SNSs, the more social capital they feel obtain. Especially, this study finds that the level of trust between SNS members plays an important role in determining an individual's decision to share information/ knowledge in SNSs. Moreover, this research confirmed that e-WOM quality has a positive impact on knowledge sharing behavior in Vietnam.

The research provides the framework of social capital to test the relationship be-tween knowledge sharing and e-WOM through SNSs in context of Vietnam. This framework is very significant because it indicates the theoretical foundation of the modeled impacts between e-WOM and Knowledge sharing through SNSs from the perspective of Social capital.

It would be a fine foundation for: Organizations, Social Managers improve their performance on managing; building a marketing of strategy; planning for Knowledge Sharing and Knowledge Management; disseminating educational content and hu-man development as well as social issues are identified.

However, there are some of limitations in this study as below:

- Convenience sampling method.
- Just focuses on Facebook, most popular SNS in Vietnam.
- Only studies one aspect of norms (collaborative norms).

Some implications for future research could be summarized as follows:

- Examine the results with other users and in other environments.
- Conduct research on other SNSs, such as Twitter, Instagram, Myspace...
- Focus on other aspects of social capital and norms.
- Conduct in other country, in the new context of social or culture.

## REFERENCES

- Adler, P.S and Kwon, S.W. (2002). Social capital: Prospects for a new concept. *Academy of Management Review*, 27(3), 17-40.



- Adhi, P. (2014). Understanding Knowledge Sharing and Social Capital in Social Network Sites. *International Journal of Science and Research*, 3(3), 750-761.
- Alavi, M. and Leidner, D. E. (2001). Review: Knowledge management and knowledge management systems: Conceptual foundations and research issues. *MIS Quarterly*, 25(1), 107-136.
- Awad, N. F. and Ragowsky, A. (2008). Establishing trust in electronic commerce through online word of mouth: An examination across genders. *Journal of Management Information Systems*, 24(4), 101-121.
- Bayus, B.L. (2012) Crowdsourcing new product ideas over time: An analysis of Dell's IdeaStorm Community. *Management Science*, 4(1), 15-24.
- Bock, G., Kankanhalli, A., and Sharma S. (2006). Are norms enough? The role of collaborative norms in promoting organizational knowledge seeking. *European Journal of Information Systems*, 15(4), 357-367.
- Boyd, D. M. and Ellison N. B. (2008). Social network sites: Definition, history, and scholarship. *Journal of Computer-Mediated Communication*, 13(1), 210-230.
- Chang C-M., Hsu M-H., Cheng H-L., and Lo C-H. (2010). Exploring the antecedents of trust in virtual communities: A theoretical model for facilitating knowledge sharing. *Proceedings of the 2010 International Conference on Business and Information*, Kitakyushu, 1-20.
- Chiu C-M., Hsu M-H., and Wang E. T. G. (2006). Understanding knowledge sharing in virtual communities: An integration of social capital and social cognitive theories. *Decision Support Systems*, 42(3), 1872-1888.
- Choi, J. H. and Scott, J. E., (2013). Electronic Word of Mouth and Knowledge Sharing on So-cial Network Sites: A Social Capital Perspective, *Journal of Theoretical and Applied Electron-ic Commerce Research*, 8(1), 69-82.
- Chow, W. S. and Chan, L. S. (2008). Social network, social trust and shared goals in organizational WOM. *Information & Management*, 45(7), 458-465.
- Chu, S-C. and Kim, Y. (2011). Determinants of consumer engagement in electronic word-of-mouth (e-WOM) in social networking sites. *International Journal of Advertising*, 30(1), 47-75.
- Coleman, J. S. (1988). Social capital in the creation of human capital. *American Journal of Sociology*, 94(1), 95-120.

- Dalkir, K. (2005): *Knowledge Management in Theory and Practice*. MA: Elsevier, Boston, 43-44.
- Donath, J. and Boyd, D. (2004). Public displays of connection. *BT Technology Journal*, 22(4), 71-82.
- Gallaugh, J. and Ransbotham, S. (2010). Social media and customer dialog management at Starbucks. *MIS Quarterly Executive*, 9(4), 197-212.
- Gefen, D., Karahanna, E., and Straub, D.W. (2003). Trust and TAM in online shopping: An integrated model. *MIS Quarterly*, 27(1), 51-90.
- Godes, D. and Mayzlin, D.(2004). Using online conversations to study word-of-mouth communication. *Marketing Science*, 23(4), 545-560.
- Hair, J.F., Anderson, R.E., Tatham, R.L. and Black (2006), *Multivariate Data Analysis*. New Jersey: Prentice-Hall, 2006
- Hennig-Thurau, T., Gwinner, K. P., Walsh, G., and Gremler, D. D. (2004). Electronic word-of-mouth via consumer-opinion platforms: What motivates consumers to articulate them-selves on the Internet? *Journal of Interactive Marketing*, 18(1), 38-52.
- Hofstede, G. (1991). *Culture's Consequences*. Newbury Park, CA: Sage Publications.
- Hsu, M-H., Ju, T. L., Yen, C-H., and Chang, C-M.(2007). Knowledge sharing behavior in virtual communities: The relationship between trust, self-efficacy, and outcome expectations. *International Journal of Human-computer Studies*, 65(2), 153-169.
- Hsu, Y. and Tran, T-H-C. (2013). Social Relationship Factors Influence on E-WOM Behaviors in Social Networking Sites: Empirical Study: Taiwan and Vietnam. *International Journal of Business, Humanities and Technology*, 3(3), 22-31.
- Huang, K., Choi, N., and Horowitz, L. (2010). Web 2.0 use and organizational innovation: A knowledge transfer enabling perspective. *Proceedings of the 16th Americas Conference on Information Systems*, 1-14.
- Hung, K. H. and Li, S. Y. (2007). The influence of e-WOM on virtual consumer communities: Social capital, consumer learning, & behavioral outcomes. *Journal of Advertising Research*, 47(4), 485-495.

- Lee, I. (2011). Overview of emerging web 2.0-based business models and web 2.0 applications in businesses: An ecological perspective. *International Journal of E-Business Research*, 7(4), 1-16.
- Leimeister, J. M., Huber, M., Bretschneider, U., and Krcmar, H. (2009). Leveraging crowdsourcing: Activation-supporting components for IT-based ideas competition. *Journal of Management Information Systems*, 26(1), 197-224.
- Lesser, E. L. and Storck, J. (2001). Communities of practice and organizational performance. *IBM Systems Journal*, 40(4), 831-841.
- Majchrzak, A., Cherbakov, L., and Ives, B. (2009). Harnessing the power of the crowds with corporate social networking tools: How IBM does it? *MIS Quarterly Executives*, 8(2), 103-108.
- Nahapiet, J. and Ghoshal, S. (1998). Social capital, intellectual capital and the organizational advantage. *Academy of Management Review*, 23(2), 242-268.
- Putnam, R. D. (2000). *Bowling Alone*. New York, NY: Simon and Schuster.
- Sherif, K., Hoffman, J., and Thomas, B. (2006). Can technology build organizational social capital? The case of a global IT consulting firm. *Information and Management*, 43(7), 795-804.
- Steenkamp, J-B.E.M., van Trijp, H.C.M., (1991). The use of LISREL in validating marketing constructs. *International Journal of Research in Marketing* 8, 283-299.
- Steffes, E. M. and Burgee, L. E. (2009). Social ties and online word of mouth. *Internet Re-search*, 19(1), 42-59.
- Sweeney, J. C., Soutar, G. N., and Mazzarol, T. (2012). Word of mouth: Measuring the power of individual messages. *European Journal of Marketing*, 46(1), 237-257.
- Verburg, R., and Andriessen, E. (2011). A Typology of Knowledge Sharing Networks in Practice. *Knowledge and Process Management*, 18(1), 34-44.